



August 13, 2021

BID21-00-16

Subject: Invitation to Bid

Prospective Bidders:

Sealed bids for furnishing items and/or services on attached forms will be received in the **Purchasing Department of the Birmingham Water Works Board, located at 3600 First Avenue North, Birmingham, Alabama until 10:00 a.m., Wednesday, August 25, 2021** at which time and place they will be publicly opened and read.

Due to COVID-19 a WebEx meeting has been set up or you may call 1-408-418-9388; Access Code – 1460707667. Please call in 5 minutes prior to the bid opening.

“Specifications and Conditions” and “Bid Form” are attached. One copy of the “Bid Form” should be returned, the other retained by the bidder.

All bids should be **quoted F.O.B. destination, freight prepaid and no charge.** The right is reserved to reject any or all bids submitted, to waive any informalities and technicalities, and to award to the bidder it is deemed will best and most economically serve the Board’s interests. The Board reserves the right to award the bid on an individual or total cost of bid basis. The Board also reserves the right to exercise its option to extend the contract up to two (2) additional years with the mutual consent of both parties and the Board will also have the option of canceling this contract in thirty (30) days with written notice. The Board also reserves the right to Re-Bid.

Bids must be mailed to 3600 1st Avenue North, Birmingham, Alabama 35222, directed to the attention of the **Purchasing Manager**, and marked in the lower left-hand corner of the envelope as follows: **Quotation on “Curb Boxes, Valve Boxes & Extensions and Pavadjusters” due at 10:00 a.m., Wednesday, August 25, 2021.**”

Yours very truly,

A handwritten signature in blue ink, appearing to read 'Raymond Q. Childs', written over the typed name.

Raymond Q. Childs
Purchasing Supervisor
RQC/ba

DATE: August 13, 2021

**SPECIFICATIONS AND CONDITIONS
CURB BOXES AND LIDS**

MUST BE SHIPPED ON OPEN TOP TRUCK.

Curb boxes shall be City of Birmingham patterns. Drawings for boxes required are attached and covers must be in compliance with same.

Length of top section shall be 12" to 14".

Length of bottom section shall be 14".

Lids for above curb boxes shall be marked "Water".

Extension of valve boxes shall be 12" and 18" in length.

Cast iron shall conform to A.S.T.M. Specifications A-48 for Class 20 gray iron castings or latest revision thereof. All castings shall be true and free of holes. They shall be cleaned according to good foundry practice, chipped and ground as needed to remove fins and rough places on castings. The castings shall be coated with a coal tar paint that is applied cold and be smooth and not brittle or sticky at any temperatures. Coatings shall conform to AWWA Specifications C104-53 or latest revision thereof.

In the interest of standardization, curb boxes shall be as those manufactured by Opelika Foundry, now Bingham & Taylor or approved equal, and must be interchangeable with those existing in our system.

The successful bidder shall be in a position to furnish, upon request of the Water Works Board, samples of proposed boxes and lids prior to first shipment. Samples shall be approved by Mr. Reis Logan or his designated representative.

Prices quoted shall be F.O.B. destination, which is the Warehouse address of 3505 Messer Airport Highway, deliver thru entrance at 3500 Second Avenue North, Birmingham, Alabama 35222.

All above items must be shipped in crates or pallets on a flatbed truck and any additional charges must be included in the unit price quoted for each item.

Individual crates, pallets, bundles or packages shall not exceed 2,500 lbs. each.

*If bidding a product manufactured by another firm, you must submit a letter from the manufacturer of that product giving your company as agent authority to bid that product.

Letter may be a blanket letter from manufacturer renewable at the beginning of the calendar year giving your company authorization to bid on and sell the products that you are quoting. This letter may cover as many items as are represented by your company.

In case of default by the vendor, the Board may procure the articles or services from other sources and may deduct from any monies due, or that may thereafter become due to the vendor, the difference between the price named in the contract or purchase order and the actual cost thereof to the Board. Prices paid by the Board shall be considered the prevailing market price at the time such purchase is made.

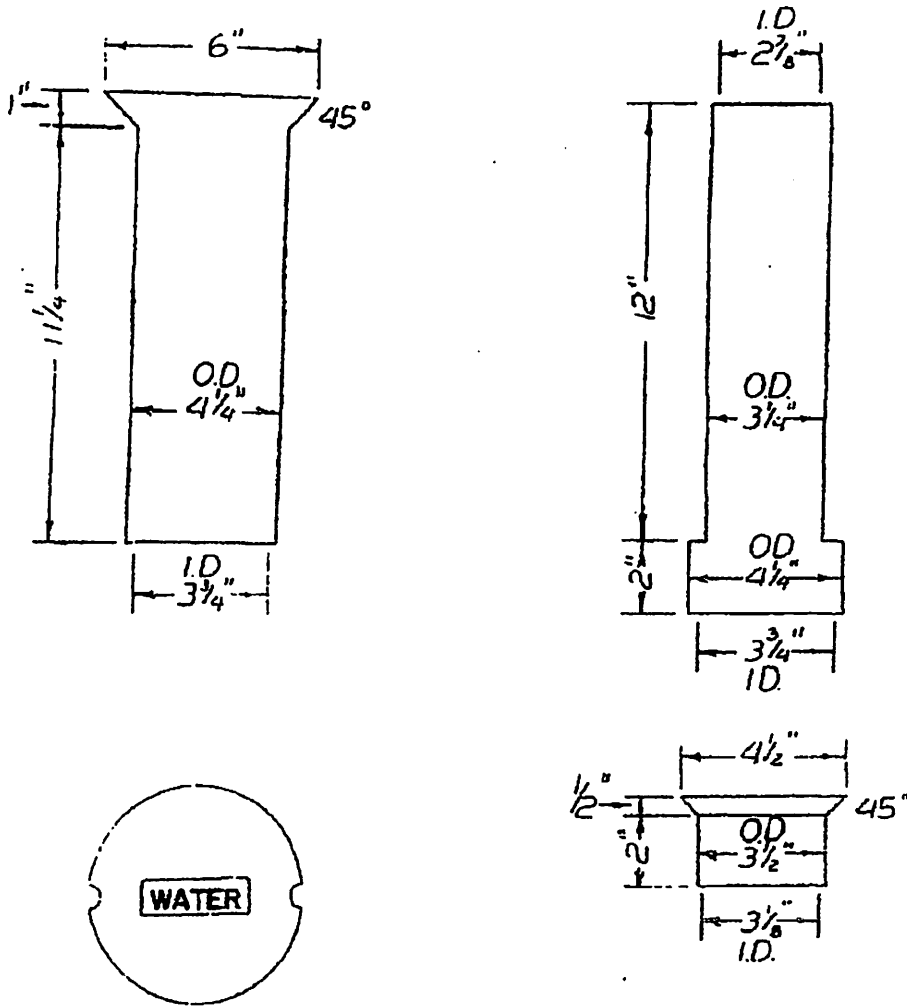

BIRMINGHAM CURB BOX

THE WATER WORKS BOARD OF THE CITY OF BIRMINGHAM

SEC _____ AP _____ SCALE 1/4" = 1'-0" WO _____ DATE 5-1-75 DRAWN BY D. E.

DATE: August 13, 2021

SPECIFICATIONS AND CONDITIONS
VALVE BOXES AND VALVE BOX EXTENSIONS

MUST BE SHIPPED ON OPEN TOP TRUCK.

Valve boxes shall be of cast iron, two piece, screw type, 5-1/4" diameter and extend 24" – 36" with a minimum weight of 80 pounds.

Top sections for valve boxes described above shall be 15" and have a minimum weight of 29 pounds.

Bottom sections for valve boxes described above shall be 24" long and have a minimum weight of 33 pounds.

Covers for above described valve boxes shall be marked "Water" and have a sta-put skirt, and have a minimum weight of 14 pounds.

Extension of valve boxes shall be 12" and 18" in length.

Drawings for above required valve boxes and extensions are attached.

Cast iron shall conform to A.S.T.M. Specifications A-48 for Class 20 gray iron castings or latest revision thereof. All castings shall be true and free of holes. They shall be cleaned according to good foundry practice, chipped and ground as needed to remove fins and rough places on castings. The castings shall be coated with a coal tar paint that is applied cold and be smooth and not brittle or sticky at any temperatures. Coatings shall conform to AWWA Specifications C104-53 or latest revision thereof.

In the interest of standardization, valve boxes shall be the No. 20 manufactured in Opelika, Alabama by **Opelika Foundry, now Bingham & Taylor or approved equal**, and must be interchangeable with those existing in our system.

The successful bidder shall be in a position to furnish, upon request of the Water Works Board, samples of proposed boxes and lids prior to first shipment. Samples shall be approved by Mr. Reis Logan or his designated representative.

Prices quoted shall be F.O.B. destination, which is the Warehouse address of 3505 Messer Airport Highway, deliver thru entrance at 3500 Second Avenue North, Birmingham, Alabama 35222.

Individual crates, pallets, bundles or packages shall not exceed 2,500 lbs. each.

*If bidding a product manufactured by another firm, you must submit a letter from the manufacturer of that product giving your company as agent authority to bid that product.

Letter may be a blanket letter from manufacturer renewable at the beginning of the calendar year giving your company authorization to bid on and sell the products that you are quoting. This letter may cover as many items as are represented by your company.

In case of default by the vendor, the Board may procure the articles or services from other sources and may deduct from any monies due, or that may thereafter become due to the vendor, the difference between the price named in the contract or purchase order and the actual cost thereof to the Board. Prices paid by the Board shall be considered the prevailing market price at the time such purchase is made.

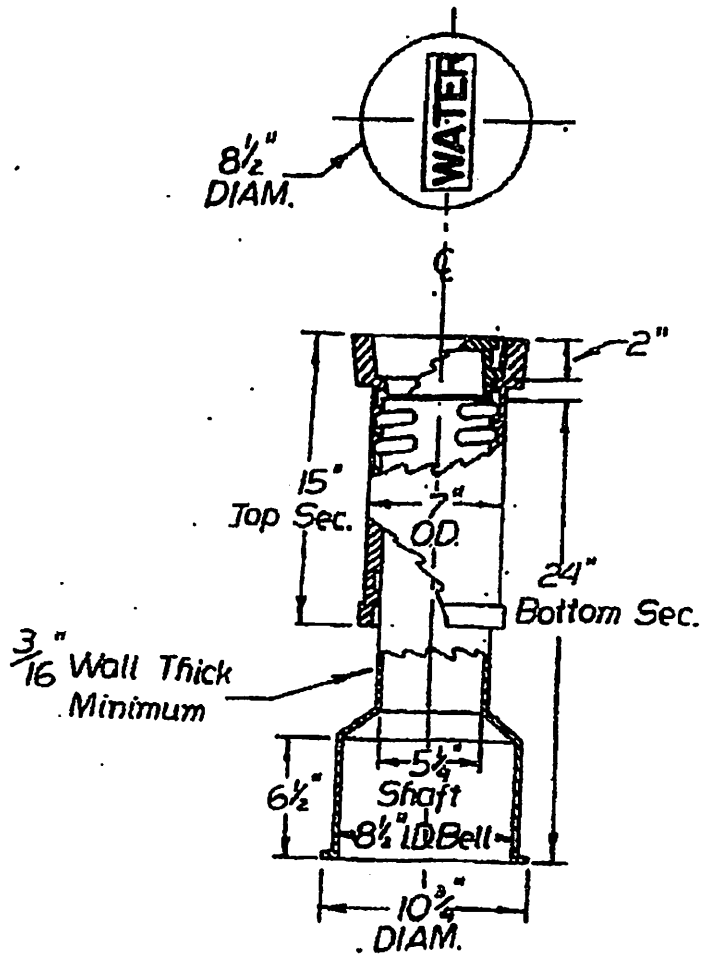

NO. 20 5 1/4"
 Screw Type Valve Box
 FOR VALVES UP TO 12" IN SIZE.
 EXTENSION 24" TO 36"

VALVE BOX EXTENSION

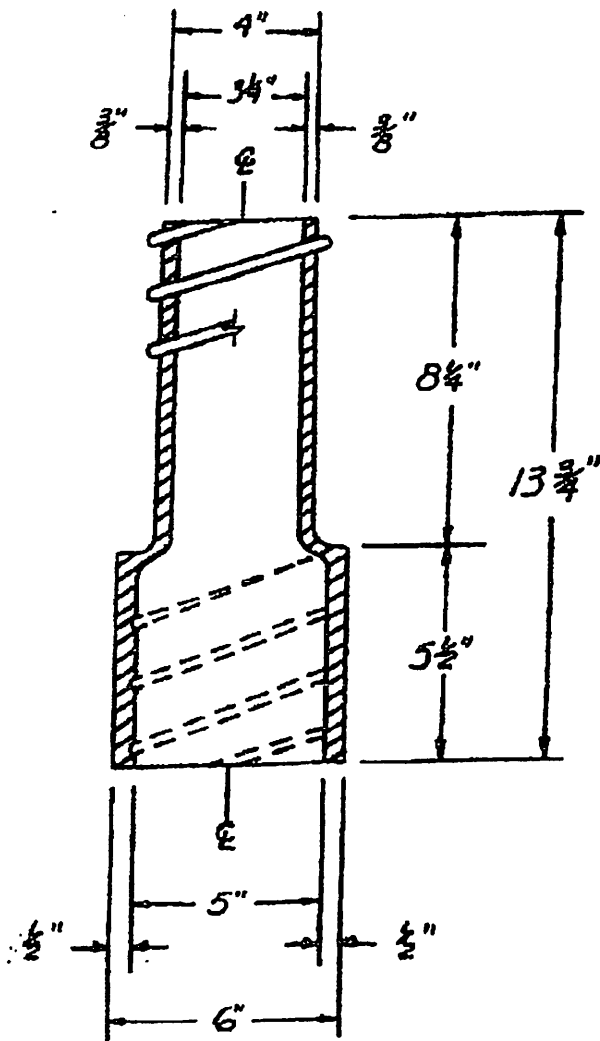

THE WATER WORKS BOARD OF THE CITY OF BIRMINGHAM

EC. _____ AP. _____ SCALE 3" = 1'-0" W.O. _____ DATE 11-16-87 DRWN. BY J. Manley

Date: August 13, 2021

SPECIFICATIONS AND CONDITIONS
PAVADJUSTERS AND LIDS

DOMESTIC MANUFACTURER

The Water Works Board of the City of Birmingham uses Cast iron Pavadjusters and Lids as a standard and shall be the 'round' type without lips or flanges. The word "Water" shall be cast into the lids.

They shall be cast from Class 20-A iron, ASTM Specifications A-48.75, Federal Specifications Q.Q.F.-652A. All parts shall be bituminous coated.

In the interest of standardization, all proposed pavadjusters and lids shall be cast to the dimensions shown on the attached drawing and must be inter-changeable with those existing in our system.

All shipments must be boxed or crated in such a manner that unloading may be performed with a crane or forklift and delivered on a flat bed trailer.

The successful bidder shall be in a position to furnish, upon request of the Water Works Board, samples of proposed boxes and lids prior to first shipment.

Prices quoted shall be F.O.B. destination, which is the Warehouse address of 3505 Messer Airport Highway, deliver thru entrance at 3500 Second Avenue North, Birmingham, Alabama 35222.

*If bidding a product manufactured by another firm, you must submit a letter from the manufacturer of that product giving your company as agent authority to bid that product.

Letter may be a blanket letter from manufacturer renewable at the beginning of the calendar year giving your company authorization to bid on and sell the products that you are quoting. This letter may cover as many items as are represented by your company.

In case of default by the vendor, the Board may procure the articles or services from other sources and may deduct from any monies due, or that may thereafter become due to the vendor, the difference between the price named in the contract or purchase order and the actual cost thereof to the Board. Prices paid by the Board shall be considered the prevailing market price at the time such purchase is made.

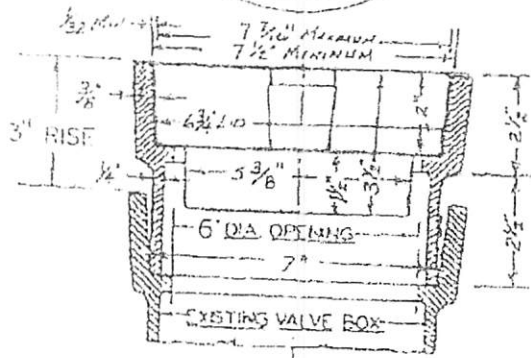

3"
PAVADJUSTER

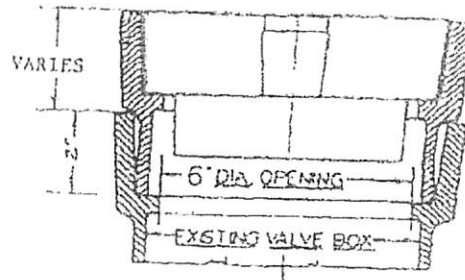
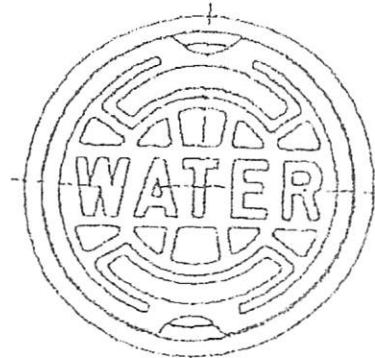

1, 1 1/2, 2, 2 1/2"
PAVADJUSTER

NOTE: All dimensions are nominal except as specified.



PAV. ADJUSTER

DRAWN BY: RT
 CHECKED BY:
 APPROVED BY:
 ENGINEER
 WORK ORDER
 DATE: 11/30/09
 D.P.
 SEC.
 SCALE: NTS
 FILE

INSERT FOR BIDS OR RFP's REGARDING SECTION 9 OR IMMIGRATION ACT

Ala. Code §31-13-9 (1975) provides that as a condition for the award of any contract, grant or incentive by the Water Works Board of the City of Birmingham, a business entity or employer that employs one or more employees within the State of Alabama, shall not knowingly employ, hire for employment, or continue to employ an unauthorized alien. You should provide documentation establishing that the business entity or employer is enrolled in the E-Verify program.

If you are not enrolled, the website is [e-verify program](#). Click on the home page. Once on the home page, click on [Enroll in E-verify](#), it will take you through the necessary steps to enroll. Print documents and submit as requested.

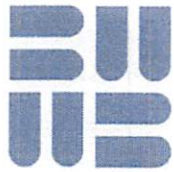

VENDOR INFORMATION INQUIRY

MBE DBE WBE NA

PLEASE INCLUDE COPY OF CERTIFICATE FROM CERTIFYING AGENCY

Federal ID#: _____

Name of Company: _____

Mailing Address: _____

City: _____ State: _____ Zip: _____

Business#: _____ Cell#: _____

Contact Person: _____ Email: _____

Type of Business (Contractor, Supplier, Manufacturer, etc.) _____

Description of Products and/or Services: _____

COMMENTS:

If you are a General or Sub Contractor, please provide your Contractor License Number:

General Contractor License #: _____

Sub-Contractor License #: _____

*The Birmingham Water Works Board
3600 1st Avenue North, Birmingham, AL 35222
Phone: (205) 244-4300 • Website: www.bwwb.org*

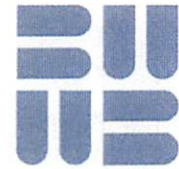

Audit Clause

BWOB and its authorized representatives shall have the right to audit, to examine, and to make copies of or extracts from all of Contractor's records (in whatever form they may be kept, whether written, electronic, or other) relating to or pertaining to HUB participation under this Contract kept by or under the control of Contractor, including, but not limited to those kept by the Contractor, its employees, agents, assigns, successors, and its subcontractors.

Such records shall include, but not be limited to, accounting records, written policies and procedures; subcontract files; all paid vouchers including those for out-of-pocket expenses; other reimbursement supported by invoices, ledgers, cancelled checks, deposit slips, bank statements, journals, original estimates, estimating work sheets, contract amendments and change order files, back charge logs and supporting documentation, insurance documents, payroll documents, timesheets, memoranda and correspondence (written and electronic).

Contractor shall, at all times during the term of this Contract and for a period of seven years after the completion of this Contract, maintain such records, together with such supporting or underlying documents and materials. Contractor shall at any time requested by BWOB, whether during or after completion of this Contract, make such records available for inspection and audit (including copies and extracts of records as required) by BWOB.

Contractor shall ensure BWOB has these rights with Contractor's employees, agents, assigns, successors, and subcontractors, and the obligations of these rights shall be explicitly included in any subcontracts or agreements formed between Contractor and any subcontractors to the extent that those subcontracts or agreements relate to fulfillment of the HUB participation under this Contract.



FUNDS PAID AND CONFLICT OF INTEREST AGREEMENT

FUNDS PAID: Agreement that no part of the funds paid by the Water Works Board pursuant to this Agreement nor any part of the services, products or any item or thing of value whatsoever purchased or acquired with said funds shall be paid to, used by or used in anyway whatsoever for the personal benefit of any member or employee of any government entity whatsoever or family member of any of them, including federal, state, county and municipal and any agency or subsidiary of any such government; and further certify that neither the Contractor nor any of its officers, partners, owners, agents, representatives, employees or parties in interest has in any way colluded, conspired, connived, with anyone or with any member of the governing body or employee of the governing body of the Water Works Board or any other public official or public employee, in any manner whatsoever, to secure or obtain this Agreement and further certify that, except as expressly set out in the scope of work or services of this Agreement, no promise or commitment of any nature whatsoever of anything of value whatsoever has been made or communicated to any such governing body member or employee or official as inducement or consideration for this contract.

Any violation of the terms and scope of services, including misuse of funds provided in this contract shall constitute a breach and default of this Agreement, which shall be cause for termination. Upon such termination of this Agreement due to breach, Contractor shall immediately refund to the Water Works Board all amounts paid by the Water Works Board pursuant to this Agreement.

CONFLICT OF INTEREST: The Contractor declares that, as of the date of the Agreement, neither the Water Works Board, nor any of the Water Works Board's employees or any director nor any other government official is directly or indirectly interested in this Agreement or any agreement with the Contractor for which compensation will be sought during the period of time this Agreement is being performed. And, furthermore, the Contractor pledges that She/he/it will notify the General Manager in writing should it come to his/its knowledge that any such official becomes either directly or indirectly interested in the Agreement or any agreement with the Contractor for which compensation will be sought during the aforesaid period. In addition, the Contractor declares, that as of the date of this Agreement, neither She/he/it nor any of her/his/its officers or employees have given or donated or promised to give or donate, either directly or indirectly, to any official or employee of the Water Works Board, or to anyone else for the Water Works Board's benefit, any sum of money or other thing of value for aid or assistance in obtaining this Agreement with the Water Works Board under which compensation will be sought during the period of time this Agreement is being performed. And furthermore, that neither the Contractor nor any of her/his/its officers or employees will give or donate or promise to give or donate, directly or indirectly, to any official or employee of the Water Works Board, or to anyone else for the Water Works Board's, Water Works Board's official, or Water Works Board's employee's benefit, any sum of money or other thing of value, for aid of assistance in obtaining any amendment to this Agreement or any other agreement with the Contractor for which compensation will be claimed during the period of time this Agreement is being performed.

(This document is for information only)

3600 1st Avenue North, Birmingham, AL 35222
(205) 244-4000 | www.bwwb.org

CERTIFICATION REGARDING DEBARMENT

(Valve Boxes, Valve Box Extensions, Curb Boxes & Pavajusters)

The below signed Bidder hereby certifies that it, its officers, directors, owners, stockholders and its principals:

(i) Are not presently debarred, suspended, proposed for debarment, declared ineligible, or voluntarily excluded from doing business with any Federal department or agency;

(ii) Have not within a three year period preceding this bid been: debarred, suspended, proposed for debarment, declared ineligible, or voluntarily excluded from doing business with any Federal department or agency; or convicted of or had a civil judgment rendered against them for: commission of fraud or a criminal offense in connection with obtaining, attempting to obtain, or performing a public (Federal, State, or local) transaction or contract; violation of Federal or State antitrust statutes or commission of embezzlement, theft, forgery, bribery, falsification or destruction of records, making false statements, or receiving stolen property; and

(iii) Are not presently indicted for, or otherwise criminally or civilly charged by a governmental entity (Federal, State or local) with commission of any of the offenses enumerated in paragraph (ii) above.

Executed on this the _____ day of _____, 2021.

BIDDER:

By: _____
Its: _____

STATE OF ALABAMA

_____ COUNTY)

BEFORE ME, a Notary Public in and for said County, in said State, hereby certifies that

_____, whose name as _____ of

_____, a corporation, is signed to the foregoing instrument, and who is known to me, acknowledged that on this day, that being informed of the contents of said instrument, as such officer and with full authority, executed the same voluntarily for and as the act of said corporation.

Given under my hand, this _____ day of _____, 2021.

Notary Public
My commission ends: _____

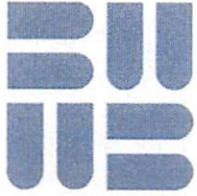

INSURANCE

Competitive Bids

Contractors shall not commence any work until all the insurance as provided herein is obtained nor until the Board has approved such insurance. Certificates issued by the Contractor's Insurance Company must be filed with the Board before any work is commenced as evidence of the insurance as provided herein. Such certificates must contain a clause stating that the Insurance Company will notify the Board ten days prior to any change, cancellation or renewal of the Contractor's insurance.

Workmen's Compensation Insurance: The Contractor shall carry Workmen's Compensation Insurance during the life of the Contract to insure statutory liability to their employees.

Comprehensive General Liability and Property Damage: The Contractor shall carry Comprehensive General Liability and Property Damage Insurance during the life of the contract covering all of the Contractor's own operations.

Comprehensive Automobile Liability and Property Damage: The Contractor shall carry Comprehensive Automobile Liability and Property Damage Insurance during the life of the contract covering (a) Contractor's own automobile equipment and (b) hired and non-owned vehicles.

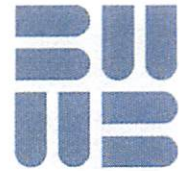

NON-DISCRIMINATION POLICY

The Birmingham Water Works Board (BWWB) values the diversity of the people with whom we work and the contributions they make. Accordingly, the BWWB is committed to providing an inclusive and welcoming environment for all members of our staff, clients, volunteers, independent contractors, and vendors.

The BWWB is an equal opportunity employer and all decisions regarding recruiting, hiring, promotion, assignment, training, termination, selection of volunteers and vendors, and other terms and conditions of employment will be made without consideration of age, sex, race, color, religion, gender, gender identity or expression, national origin, sexual orientation, disability, marital status, veteran status, pregnancy status, political opinion, work-related injury, or any other factor, characteristic or trait protected by applicable national, state or local laws.

Members of our community are encouraged to raise concerns or make complaints regarding discrimination or harassment under this policy without the fear of retaliation. It is a violation of BWWB policy to retaliate against an individual for raising a good-faith concern regarding workplace discrimination or harassment; filing a complaint for discrimination or harassment; or, for cooperating in an investigation of alleged discrimination or harassment. Any person found to be in violation of this policy is subject to disciplinary action.

Discrimination, harassment, disrespectful or inappropriate behavior, unfair treatment or retaliation of any kind will not be tolerated. This policy applies not only to BWWB employees but also to the volunteers, independent contractors, and business partners with whom we work. BWWB employees, volunteers, independent contractors and other constituents, whenever and wherever those individuals are conducting BWWB business or participating in BWWB events or activities, shall maintain an environment free of discrimination, harassment, and retaliation.

Any employee who has a question or concern regarding any type of discrimination or harassment is encouraged to bring it to the attention of his/her manager or the Human Resources Department.

BWVB CERTIFICATION OF NON-DISCRIMINATION

Vendor agrees and warrants that contractor does not discriminate or permit discrimination against any employee or applicant for employment on the grounds of race, color, religion, gender, sexual orientation, gender identity or national origin.

Authorized signature:

For: _____
Company Name (printed)

By: _____
Signature of Authorized Representative/Title

Date: _____

(Please return this form with your bid form submittal)



The Birmingham
Water Works Board

Directors/Officers

Ronald A. Mims
Chairman/President

George Munchus, Ph.D.
*First Vice-Chairman/
First Vice President*

Lucien Blankenship, Esq.
*Second Vice-Chairman/
Second Vice President*

William "Butch" Burbage, Jr., CPA
Secretary-Treasurer

Tereshia Q. Huffman
Assistant Secretary-Treasurer

Tom E. Henderson
Director

Dalton NeSmith, Jr., Esq.
Director

Chris Rice
Director

Larry Ward
Director

Michael Johnson, MBA, CPA
General Manager

**Assistant
General Managers**

Iris Fisher, CPA
Finance & Administration

Derrick M. Murphy, MEng
Engineering & Maintenance

Jeffrey F. Thompson, PE
Operations & Technical Services

RE: Request for Company Product and Service Information

To Whom It May Concern:

This correspondence is to request information on your company's profile, specific products, and services you are interested in providing to the Birmingham Water Works Board. We are honored to have the opportunity to work with you and learn more about your company's mission.

The Birmingham Water Works Board's mission states "The BWWB is committed to providing the highest quality of water to meet the needs and expectations of our customers and stakeholders. Our services enhance the economic, social and environmental well-being of the communities we serve."

The Board is very interested in discovering how your products or services can help meet its mission. Please provide details about your company's products, services, and supplier diversity program, as well as any additional documents to further explain your offerings. Per the goals of our mission to strive to be a concerned corporate citizen, please provide information on how your company has been engaged in the community, as well as the Birmingham Water Works service area.

You can learn more about the Birmingham Water Works Board at www.bwwb.org. Please submit the referenced request to Ed Travis, via email at ed.travis@bwwb.org. Please contact me if I can answer any questions. I look forward to hearing from you soon.

Sincerely,

Derrick M. Murphy, MEng
Assistant General Manager
Engineering and Maintenance Division

CC: Ed. Travis – Purchasing Manager



Supplier Diversity/Community Involvement Program Questionnaire

Supplier Diversity Program (SDP) promote supplier diversity in public contracting in a manner that develops, strengthens and increases business opportunities for Disadvantaged Business Enterprise (DBE), Minority Business Enterprise (MBE), Women Business Enterprise (WBE), and Veteran Business Enterprise (VBE). Please fill-out the following information on your company's SDP.

Bidder Name:	Project Name:
Bid/Proposal No.:	Contact Person:
Address:	Cell No.
Office No.	Email:

1. Does your company have a Supplier Diversity Program: Yes No

If yes, please provide your website or any information pertaining to your SDP.

Additional Information: _____

2. Community involvement is the power to bring positive, measurable change to both the communities in which you operate and to your business.

Please provide any involvement with the community that your company participates in: Ex: charities, scholarships, etc. (United Way, Salvation Army, Children’s Hosp., H2O Foundation, etc.)

3. Please provide a list of Minority vendors your company receives services or products from. Identify if the vendor is a MBE, WBE or DBE. Example: Jones Janitorial Services – MBE; Summer Office Supplies - WBE

_____	_____
_____	_____
_____	_____
_____	_____



BAAWBI FED REPORT

1. MARK APPROPRIATE BLOCK <input type="checkbox"/> PRIME COMPANY <input type="checkbox"/> SUB COMPANY	2. COMPANY NAME, CITY, STATE:	3. BAAWBI PROJECT/WORK LOCATION (CITY, COUNTY AND STATE)
---	-------------------------------	--

JOB CATEGORIES	TOTAL EMPLOYED		TOTAL RACIAL/ETHNIC MINORITY		BLACK OR AFRICAN AMERICAN		HISPANIC OR LATINO		AMERICAN INDIAN OR ALASKA NATIVE		ASIAN		NATIVE HAWAIIAN OR OTHER PACIFIC ISLANDER		TWO OR MORE RACES		WHITE		APPRENTICES		ON THE JOB TRAINEES	
	M	F	M	F	M	F	M	F	M	F	M	F	M	F	M	F	M	F	M	F	M	F
EXECUTIVE/SENIOR LEVEL OFFICIALS AND MANAGERS																						
FIRST/MID LEVEL OFFICIALS AND MANAGERS																						
PROFESSIONALS																						
TECHICIANS																						
SALE WORKERS																						
SKILL AND CRAFT WORKERS																						
EQUIPMENT OPERATORS																						
TRUCK DRIVERS																						
ADMINISTRATIVE SUPPORT																						
SERVICE WORKERS																						
LABORERS - SEMI SKILLED																						
LABORERS - UNSKILLED																						
TOTAL	0	0	0	0	0	0	0	0	0	0	0	0	0	0	0	0	0	0	0	0	0	0

APPRENTICES																							
OTJ TRAINEES																							
4. PREPARED BY: <i>(Signature and Title of Contractor Representative)</i>										5. DATE					6. REVIEWED BY: <i>(Signature and Title of BAAWBI Representative)</i>					7. DATE			

**GOODS AND SERVICES/PUBLIC WORKS
VENDOR CHECKLIST**

Description/Vendor:

Bid Date:

(If all forms are not returned with bid, your bid will be non-compliant)

HUB FORMS and DOCUMENTATION CHECKLIST		Yes or No	
1.	HUB Form 1 – HUB Program Acknowledgement	<input type="checkbox"/> Yes	<input type="checkbox"/> No
2.	HUB Form 2 – HUB Compliance Form	<input type="checkbox"/> Yes	<input type="checkbox"/> No
3.	HUB Form 3 – Bid Solicitation Notice (BCIA) – (Only for Public Works Bids)	<input type="checkbox"/> Yes	<input type="checkbox"/> No
4.	HUB Form 4 – Sub-Company Participation Form (Part 1 & 2)- Only for Sub-Contractors	<input type="checkbox"/> Yes	<input type="checkbox"/> No
5.	HUB Form 5 – Sub-Company Performance Form (Part 1 & 2)- Only for Sub-Contractors	<input type="checkbox"/> Yes	<input type="checkbox"/> No
6.	HUB Form 6 – Sub-Company Utilization Form (Part 1 & 2) – Public Works Bids only HUB Form 6- Direct Manufacturer/Supplier Certification (Goods & Service Bids only)	<input type="checkbox"/> Yes	<input type="checkbox"/> No
7.	HUB Form 7 – Hub Compliance Form – (Only for Public Works Bids)	<input type="checkbox"/> Yes	<input type="checkbox"/> No
8.	HUB Form 8 – Prime Company Monthly Report – (Only for Public Works Bids)	<input type="checkbox"/> Yes	<input type="checkbox"/> No
9.	HUB Form 9 – Prime Close-out Report – (Only for Public Works Bids)	<input type="checkbox"/> Yes	<input type="checkbox"/> No
10.	EEO Report	<input type="checkbox"/> Yes	<input type="checkbox"/> No
11.	Supplier Diversity Program Questionnaire	<input type="checkbox"/> Yes	<input type="checkbox"/> No
12.	Certification of Non-Discrimination	<input type="checkbox"/> Yes	<input type="checkbox"/> No
13.	Debarment Form	<input type="checkbox"/> Yes	<input type="checkbox"/> No

THE WATER WORKS BOARD OF THE CITY OF BIRMINGHAM
HISTORICALLY UNDERUTILIZED BUSINESS PROGRAM

General Mission Statement

The Water Works Board of the City of Birmingham ("BWVB") has adopted a voluntary Historically Underutilized Business ("HUB") Program designed to encourage the participation of HUB firms in construction projects and goods and services. To that end, the BWVB will not exclude any firm from participation in, deny any person benefits of, or otherwise discriminate in connection with the award and performance of BWVB construction contracts and goods and services bids based on racial, gender, social, or economic status.

It is the intent of the BWVB to foster competition among contractors, suppliers and vendors that will result in better quality and more economical services for the BWVB. Under this program, the BWVB has established a goal of 30% participation of HUB firms for services required for BWVB construction projects and goods and services. The BWVB's stated goal will not be the determining factor in construction and goods and services contract awards; rather bidders must demonstrate compliance with the Good Faith Efforts, more particularly outlined below, toward meeting said goal.

Failure on the part of a bidder to fully submit the information required herein may be considered by the BWVB in evaluating whether the bidder is responsive to bid requirements.

NOTE: If Bidder is a direct manufacturer/direct supplier of the goods or services sought in this Bid and has no opportunities for HUB participation, Bidder should fill out the Direct Manufacturer/Supplier Certification Form 6.

Program Goals

- To ensure nondiscrimination in the award and administration of BWVB construction contracts and goods and services.
- To help to remove barriers to the participation of HUB firms in receiving BWVB construction contracts and bids for goods and services.
- To create a level playing field on which HUB firms can compete fairly for BWVB construction contracts and bids for goods and services.

Definitions

1. Historically Underutilized Business (HUB): A business formed for the purpose of making a profit and is at least 51% owned, operated and/or controlled by one or more American citizens or permanent resident aliens who are: Minority Business Enterprise (MBE); Women's Business Enterprise (WBE); Disadvantaged Business Enterprise (DBE) and Disable Veteran Business Enterprise (DVBE); (herein sometimes collectively referred to as HUB).
2. Minority Business Enterprise (MBE): A business that is formed for the purpose of making a profit and is at least 51% owned, operated and/or controlled by a person who is a member of the following groups: African/Black Americans; Hispanic Americans; Asian Pacific Americans; Subcontinent Asian Americans; Native Americans or American Women.

3. Disadvantaged Business Enterprise (DBE): A business that is formed for the purpose of making a profit and is at least 51% owned, operated and/or controlled by one or more socially and/or economically disadvantaged individuals. A socially disadvantaged individual is one who has been a subject of racial, ethnic or gender bias because of their membership in a group. An economically disadvantaged individual is one whose ability to compete in the free enterprise system is impaired due to diminished opportunities to obtain capital and credit.
4. Women's Business Enterprise (WBE): A business enterprise formed for the purpose of making a profit and is at least 51% owned, operated and/or controlled by American citizens or permanent resident aliens who are women.
5. Birmingham Construction Industry Authority (BCIA): The BCIA (Website www.bcial.org) is a voluntary program developed to maximize HUB participation in the construction industry of the Birmingham area. Owners of construction projects in both the public and private sector participate in the BCIA's efforts to increase the participation of HUB in their construction projects. HUB firms are certified as MBE, DBE or WBE by the BCIA and receive business counseling and technical assistance provided by the BCIA staff.

Resources for Identifying HUB Participants

Each bidder/prime contractor must contact BCIA for assistance in identifying HUB participants. In addition to the BCIA, the following are resources for identifying HUB participants. Each bidder/prime contractor must show proof that where appropriate, these other resources were contacted for assistance in identifying Hub participants. The other resources are:

1. **Alabama State Black Chamber of Commerce**; Jerry Mitchell, Email: wehelp@alblackcc.org; Website: admin@naaaachamber.org; Phone: (256) 551-0673
2. **Alabama Department of Economic and Community Affairs, Office of Minority Business Enterprise**, Mr. Scott Stewart, Manager; Phone (334) 353-3966; FAX (334) 353-4311
Email; Scott.stewart@adeca.alabama.gov
3. **Birmingham Airport Authority**; Phone (205) 595-0533; FAX (205) 599-0538
Website: info@flybirmingham.com
4. **Alabama Department of Transportation Disadvantaged Business Enterprises**; John Huffman
Phone: (334) 242-6251; FAX (334) 242-6256; Email: huffmanjo@dot.state.al.us
Website: www.dot.state.al.us
5. **Department of Innovation & Economic Opportunity**; Coreata Houser, Deputy Director
Phone (205) 254-2799; FAX (205) 254-7741; Email: coreata.houser@birminghamal.gov
6. **Alabama Department of Transportation**; Phone (334) 244-6261
Website: www.dot.state.al.us
7. **Governor's Office of Minority and Women's Business Enterprises**
Phone 1-800-447-4191 and (334) 242-2220; FAX (334) 242-4203
8. **U.S. Department of Commerce Minority Business Development Agency**
Phone: (404) 730-3300; FAX (404) 730-3313; Website: www.mbda.gov
9. **U.S. Small Business Administration, Alabama District Office**
Phone: (205) 290-7101; FAX (205) 290-7404; Email: Carol.house@sba.gov
Website: www.sba.gov/offices/district/al/birmingham

10. U.S. Department of Transportation Office of Small and Disadvantaged Business Utilization
Phone: (202) 366-7228; FAX (202) 366-7228
11. National Association of Minority Contractors; Website: www.name-atl.org
12. BCIA (Birmingham Construction Industry Authority) Contact: Kimberly Baylor Bivins,
kbaylorbivins@bcia1.org; or Ashley Orl, aorl@bcia1.org
13. Minority Supplier Development Council Southern Regions; Contact Mark Samuels;
Phone (504) 293-0404; FAX (504) 293-0401; Email: msamuel@srmsdc.org
14. Birmingham Business Resource Center; Website: www.mybbrc.biz; Contact: Brandon Pettagruie,
brandon@bbrc.biz or Bob Dickerson, bdickerson@bbrc.biz, 205-250-6380 ext. 6610

Affirmative Steps for Good Faith Solicitation

All bidders must submit to BWWB in their sealed bids evidence of the following Affirmative Steps taken to utilize HUB's. These Affirmative Steps are required methods to ensure that HUB's have the opportunity to compete for contracts with BWWB.

It is up to BWWB to make a fair and reasonable judgement whether a bidder/prime company made adequate good faith efforts. The BWWB will consider the quality, quantity, and intensity of the different kinds of efforts that the bidder/prime company made. The efforts employed by the bidder/prime company should be those that one could reasonably expect a bidder/prime company to take if the bidder/prime company were actively and aggressively trying to obtain HUB participation sufficient to meet the HUB Program goals.

Below is a list of types of steps that BWWB will consider as part of the bidder's/prime company's good faith efforts to obtain HUB participation. It is not intended to be a mandatory checklist, nor is it intended to be exclusive or exhaustive. Other factors or types of efforts may be relevant in appropriate cases:

1. Ensure HUB's are made aware of contracting opportunities to the fullest extent practicable through outreach and recruitment activities. Soliciting through all reasonable and available means (e.g. attendance at pre-bid meetings, advertising, written notices and notifying BCIA, or other available sources) the interest of all certified HUB's who have the capability to perform the work of the contract. The bidder/prime company must solicit this interest within sufficient time to allow the HUB's to respond to the solicitation. The bidder/prime company must determine with certainty if the HUB's are interested by taking appropriate steps to follow up initial solicitations.
2. Make information on forthcoming opportunities available to HUB's and arrange time frames for the submission and finalization of contracts and established delivery schedules, where the requirements permit, in a way that encourages and facilitates participation by HUB businesses in the competitive process. This includes, at a minimum, seeking and receiving solicitations for contract bids or proposals 2 calendar days before sealed bids are due to BWWB.
3. Once the contract has been awarded, the prime company should continue to use its best efforts to further increase HUB participation toward reaching the BWWB stated goal.
4. Consider in the bidding process when competing for large contracts the possibility of dividing total requirements whenever economically feasible into smaller tasks or quantities to permit maximum participation by HUB's in the competitive process.

5. Encourage contracting with a consortium of HUB's when a contract is too large for one such firm to handle individually.
6. Negotiate in good faith with interested HUB sub-companies. Evidence of such good faith negotiations should include the names, addresses, and telephone numbers of HUB sub-companies that were considered; a description of the information provided regarding the request for proposal, request for qualifications, plans and specifications for the work selected for contracting; and evidence as to why additional agreements could not be reached for HUB sub-companies to perform the work.
7. Use the resources of the BCIA and the other resources identified above.
8. Provide documented proof of steps taken to comply with items 1 through 7 above.

Bidders/Prime companies must submit or provide the following HUB Forms as outlined below:

- 1) **Acknowledgement of HUB Program (HUB Form 1)**. All bidders are to read, sign and include in their sealed bid the Acknowledgement of HUB Program, indicating that they fully understand and will voluntarily participate in and follow the guidelines and instructions included in the BWB HUB Program.
- 2) **HUB Compliance Form (HUB Form 2)**. This form must be completed and included with all sealed bids for goods and services/public works with the BWB.
- 3) **HUB BID SOLICITATION NOTICE (HUB FORM 3)**. All bidders shall complete this form and submit to the BWB and the BCIA no later than seven (7) days after the scheduled date of the pre-bid conference. This form may be submitted in person at the pre-bid conference. Prospective bidders are to submit with their bid documents a copy of their HUB Form 3 with acknowledgement of receipt box completed by BCIA. (This form is used for Public Works bids only)
- 4) **HUB Sub-company Participation Form (HUB Form 4- (Part 1&2))**. This form gives a HUB sub-company the opportunity to describe the work the HUB sub-company received from the bidder/prime company, how much the HUB sub-company was paid, and any other concerns the HUB sub-company might have. Bidder/prime company shall provide copies of HUB Form 4 to all HUB sub-companies.
- 5) **HUB Sub-company Performance Form (HUB Form 5)- (Part 1&2)**. This form captures an intended HUB sub-company's description of work to be performed for the bidder and the price of the work proposed to be performed by the HUB sub-company. This form is to be provided by the bidder to each HUB sub-company and submitted along with the HUB Compliance Form included in the bid documents.
- 6) **HUB Direct Manufacturer/Supplier Certification (HUB Form 6)**. This form captures the direct manufacturers or suppliers of goods and services sought in the bid and have no distributors, wholesalers, retailers or other intermediaries, and thus do not have any opportunities for HUB participation in this Bid. (This form is used for Goods and Services bids only)

7) HUB Sub-company Utilization Form (HUB Form 6- (Part 1&2)). This form captures the bidder's/prime company's intended use of an identified HUB sub-company and the estimated dollar amount of the work. This form is to be completed by the bidder/prime company and submitted with the HUB Compliance Form included in the bid documents.

(This form is used for Public Works bids only)

8) Changes to Approved HUB Compliance Form (HUB Form 7). If any changes, substitutions, or additions are proposed to the sub-company identified in the bid or any other time during the work, the bidder/prime company must submit this information to BWWB for prior written approval. No changes to the sub-company can occur without the BWWB's prior written consent.

(This form is used for Public Works bids only)

9) Monthly Report Form (HUB Form 8). With each monthly pay request submitted to BWWB, the prime company is required to submit updated monthly **HUB Form 8** reports which identify HUB firms' participation. Monthly pay requests **will not be processed** without the updated list of HUB firms.

(This form is used for Public Works bids only)

10) Project Close-out Report (HUB Form 9). Upon completion of the contract and prior to final payment or release of retainage, the prime company is required to submit a **HUB Form 9** Project Close-Out Report that includes a final listing of all HUB participants on the project. The Project Close-Out Report, with documented HUB participation, is a prerequisite to process the final pay request.

(This form is used for Public Works bids only)

Sub-companies must be certified as HUBs in order to be counted toward the bidder's/prime company's HUB accomplishments.

The documentation of the good faith solicitation efforts must be detailed in order to allow for satisfactory review. Such documentation might include fax confirmation sheets, copies of solicitation letters/emails, printouts of the online solicitations, printouts of online search results, affidavits of publication in newspapers, etc. The bidder/prime company is strongly encouraged to follow up on each written, fax, or email solicitation with at least one logged phone call.

The bidder/prime company must employ the affirmative steps set out above to subcontract with HUB, even if the bidder/prime company has met its goal of HUB participation.

If a HUB sub-company fails to complete work under the subcontract for any reason, the prime company must notify BWWB in writing prior to any termination and must employ the good faith efforts described above if using a replacement sub-company. Any proposed changes from an approved HUB sub-company must be reported to BWWB on the Changes to Approved HUB Compliance Form (**HUB Form 7**) prior to initiation of the action.

HUB FORM 1

HUB PROGRAM ACKNOWLEDGEMENT

The Water Works Board of the City of Birmingham ("BWVB") has initiated a program to encourage the participation of HUB companies (as that term is defined in the HUB Program) on BWVB's Goods and services/Public works bids. This signed statement serves as an acknowledgement by the undersigned bidder/Prime company that it fully understands and will voluntarily participate in and follow the guidelines and instructions included in the BWVB HUB Program.

Submitted by: _____ Company: _____

Signed by: _____

HUB COMPLIANCE FORM 2 INSTRUCTIONS

Please submit the following with the HUB COMPLIANCE FORM:

- (1) List of all committed and uncommitted subcontractors by trade, including company name, address, telephone number, contact person, dollar amount of subcontract, and HUB status. Indicate in writing if no solicitations were made because the contractor intends to use only its own forces to accomplish the work.**
- (2) Proof of HUB certification for each subcontractor listed as a HUB.**
- (3) Documentation of solicitation effort for prospective HUB firms, such as fax confirmation sheets, copies of solicitation letters/emails, printout of the online solicitations, printouts of online search results, affidavits of publication in newspapers, etc. The prime contractor is strongly encouraged to follow up each written, fax, or email solicitation with at least one logged phone call.**
- (4) Justification for not selecting a certified HUB subcontractor that submitted a low bid for any subcontract area.**
- (5) HUB Form 5 – HUB Subcontractor Performance Form.**
- (6) HUB Form 6 – HUB Subcontractor Utilization Form.**

HUB FORM 2

HUB COMPLIANCE FORM

ALL INFORMATION OUTLINED ON THIS FORM IS REQUIRED FOR HUB COMPLIANCE. THE PROPOSED BIDDER/PRIME COMPANY SHOULD ENSURE THAT THIS INFORMATION IS COMPLETE PRIOR TO SUBMITTAL.

CERTIFICATIONS:

I certify that the information submitted on and with this form is true and accurate and that this firm has met and will continue to meet the conditions of this contract regarding HUB solicitation and utilization. I further certify criteria used in selecting sub-companies and suppliers were applied equally to all potential participants and that HUB Sub-company Participation Form (HUB Form 4) and HUB Sub-company Performance Form (HUB Form 5) were distributed to all HUB contractors.

(Bidder/Prime Company signature)

Date: _____

(Printed name and title)

GENERAL INFORMATION:

Owner contact: _____

Owner phone number/email: _____

Bidder/prime company: _____

Bidder/prime company contact: _____

Bidder/prime phone number/email: _____

Bidder/prime company bid amount: \$ _____

Proposed HUB Sub-company participation amount: \$ _____ Percentage: ____ % Goal: 30%

HUB FORM 3

THE WATER WORKS BOARD OF THE CITY OF BIRMINGHAM
HUB BID SOLICITATION NOTICE
(This form is used for Public Works Bids Only)

BWWB PROJECT:

LOCATION: Birmingham, Alabama

BID DATE:

To: Birmingham Construction Industry Authority (BCIA)
601 37th Street South
Birmingham, Alabama 35222
BCIA Fax: (205) 324-6210
Website: www.bcial.org
kbaylorbivins@bcial.org or aorl@bcial.org

cc: Fax # or email for Buyer

We hereby request assistance from the BCIA in securing proposals from HUB firms per the below listing of construction specialties. In order to be considered, proposals must be received in the Office of the General Contractor on or before the below listed date and time.

Please contact the following for additional information and assistance:

General Contractor/Contact:

Address:

Telephone: _____ Fax: _____

DEADLINE FOR RECEIPT OF PROPOSALS FROM HUB firms:

Date: _____ Time: _____

General Contractor Signature and Date

FOR BCIA USE ONLY

Date Received: _____

By: _____

HUB BID FORM 3 SOLICITATION NOTICE CATEGORIES
(Only for Public Works Bids)

Check all categories that apply to the referenced project:

- Demolition: _____
- Dewatering: _____
- Geotechnical Work: _____
- Material Testing: _____
- Site Clearing and Grubbing: _____
- Grading/Earthwork: _____
- Erosion Control/Silt Fence: _____
- Fencing: _____
- Grassing: _____
- Landscaping/Plantings: _____
- Pavement Striping/Marking: _____
- T.V. Inspection: _____
- Prep Manholes for Rehabilitation: _____
- Pipe Point Repairs: _____
- Hauling/Trucking: _____
- Concrete Curb & Gutter: _____
- Concrete Sidewalks: _____
- Pour & Finish Concrete Flat Work: _____
- Concrete Formwork: _____
- Install Reinforcing Steel: _____
- Point, Patch & Rub Concrete: _____
- Cementitious Coatings: _____
- Masonry Work: _____
- Wood Cabinets: _____
- Asphalt Shingle Roofing: _____
- Built-up Roofing: _____
- Metal Roofing: _____
- Gutters and Downspouts: _____
- Waterproofing/Dampproofing: _____
- Insulation: _____
- Glass & Glazing: _____
- Gypsum Wall Board System: _____
- Ceramic/Quarry Tile: _____
- Resilient Flooring: _____
- Acoustical Ceilings: _____
- Carpet: _____
- Wall Coverings: _____
- Painting: _____
- HVAC: _____
- Plumbing: _____
- Electrical: _____
- Underground Duct Banks: _____
- Material Supply: _____
- Other: _____

HUB FORM 4
HUB Sub-Company Participation Form (Part 1)

Bidders/prime companies must provide this form to its HUB sub-companies. This form gives a HUB sub-company the opportunity to describe work received and/or report any concerns regarding the project (e.g., in areas such as termination by prime company, late payments, etc.). The HUB sub-company can complete and submit this form to BWB at any time during the project period of performance.

Sub-Company Name:		Bid Name:	
Bid/Proposal No.		Point of Contact:	
Address:			
Telephone No.		Email Address:	
Prime Company Name:			

Contract Item Number	Description of Work Received from the Prime Company Involving Construction, Services, Equipment or Supplies	Amount Received by Prime Company

HUB Form 5

HUB Sub-Company Performance Form (Part 1)

This form is intended to capture the HUB Sub-company's description of work to be performed and the price of the work submitted to the HUB. Bidder/Prime company must require its Sub-company to complete this form and include all completed forms in the sealed bid package.

Sub-Company Name:	Bid Name:
Bid/Proposal No.	Point of Contact:
Address:	
Telephone No.	Email Address:
Bidder Name:	

Contract Item Number	Description of Work Submitted to the Bidder/Prime Company Involving Construction, Services, Equipment or Supplies	Price of Work Submitted to Bidder/ Prime Company

HUB Sub-Company Performance Form 5 (Part 2)

I certify under penalty of perjury that the forgoing statements are true and correct. Signing this form does not signify a commitment to utilize the Sub-company above. Bidder/Prime company is aware that in the event of a replacement of a Sub-company; it will adhere to the replacement requirements set forth in HUB program.

Bidder/Prime Company Signature	Print Name
Title	Date

Sub-company Signature	Print Name
Title	Date

If this form does not apply, please write NA, sign and return

HUB FORM 6 (GOODS AND SERVICES)
DIRECT MANUFACTURER/SUPPLIER CERTIFICATION

I/we hereby certify that we are direct manufacturers or suppliers of the goods or services sought in this Bid and have no distributors, wholesalers, retailers or other intermediaries, and thus do not have any opportunities for HUB participation in this Bid.

Bidder Name		Bid/Contract Name	
Bid/Proposal No.		Point of Contact	
Address			
Telephone No.		Email Address	

Please use the space below to explain the details about your business and why there are no HUB opportunities for your bid:

Bidder Signature	Print Name
Title	Date

Form 6

HUB Sub-Company Utilization Form (Part 1)

This form is intended to capture the bidder's/Prime company actual and/or anticipated use of identified certified HUB Sub-company, the date the HUB Sub-company submitted the bid or proposal, and the estimated dollar amount of each contract. This form must be completed and included in the sealed bid package. Bidder/Prime company should also maintain a copy of this form on file.

Company Name:	Bid Name:
Bid/Proposal No.	Point of Contact:
Address:	
Telephone No.	Email Address:

I have identified potential HUB certified Sub-companies	<input type="radio"/> Yes	<input type="radio"/> No		
If yes, please complete the table below. If no, please explain:				
Sub-Company Name/ Company Name	Company Address/Phone/Email	Solicitation Date	Est. Dollar Amt.	Currently HUB Certified Y/N

Continue on back if needed

HUB Subcontractor Utilization Form 6 (Part 2)

I certify under penalty of perjury that the forgoing statements are true and correct. Signing this form does not signify a commitment to utilize the Sub-company above. I am aware of that in the event of a replacement of a Sub-company; I will adhere to the replacement requirements set forth in HUB Program.

Bidder/Prime Company Signature	Print Name
Title	Date

HUB Form 7

Changes to Approved HUB Compliance Form
(Only for Public Works Bids)

CERTIFICATIONS:

I certify that the information submitted on and with this form is true and accurate and that this firm has met and will continue to meet the conditions of this contract regarding HUB solicitation and utilization. I further certify that criteria used in selecting Sub-companies were applied equally to all potential participants.

_____ Date _____
(Prime Company signature)

(Printed name and title)

GENERAL INFORMATION:

- (1) If an approved Sub-company is terminated or replaced, please identify this company and briefly state reason.
- (2) For new or additional Sub-companies, list name, trade, address, telephone number, contact person, dollar amount of contract, and HUB status.
- (3) Attach proof of HUB certification for each Sub-company listed as a HUB.
- (4) Attach documentation of solicitation effort for prospective HUB firms, such as fax confirmation sheets, copies of solicitation letters/emails, printouts of the online solicitations, printouts of online search results, affidavits of publication in newspapers, etc. The prime company is strongly encouraged to follow up each solicitation with at least one logged phone call.
- (5) Provide justification for not selecting a certified HUB Sub-company that submitted a low bid for any contract area.

NO BID

If you are not bidding on this service/commodity, please complete and return this form to: **Birmingham Water Works, Attn: Purchasing Manager, 3600 First Avenue North, Birmingham, Alabama 35222.** All Statement of No Bid forms must be received prior to the bid opening.

Failure to respond may result in deletion of vendor's name from the Vendor/Contractor's list for the Birmingham Water Works Board.

Company Name: _____

Address: _____

Telephone: _____

Date: _____

We, the undersigned have declined to respond to your Bid No. _____ for
_____ because of the following reasons.
(Service/Commodity)

_____ Specifications too "tight", i.e., geared toward one supplier or manufacturer only.
(explain below)

_____ Insufficient time to respond to the Bid.

_____ We do not offer this product/service.

_____ Specifications unclear. (explain below)

_____ Unable to meet bond requirements.

_____ Other (specify below)

REMARKS: _____

BY: _____ Signed: _____
(Print or Type)

August 13, 2021

BID21-00-16

BID FORM

Edward Travis, Purchasing Manager
 The Water Works Board of the City of Birmingham
 3600 First Avenue North
 P. O. Box 830110
 Birmingham, Alabama 35283-0110

Submitted below is our firm bid for items and/or services, which are in accordance with your **“Invitation to Bid” and “Specifications and Conditions” for Valve Boxes, Valve Box Extensions, Curb Boxes and Pavadjusters dated August 13, 2021.** The undersigned has read and understands said “Invitation to Bid” and “Specifications and Conditions” and expressly agrees to be bound by the terms thereof.

<u>DIV/PC/ITEM</u>	<u>Quantity</u>	<u>Description</u>	<u>Manufacturer</u>	<u>Unit Price</u>	<u>Total Price</u>
200371	75 ea.	Curb Box – Lid Only	_____	\$ _____	\$ _____
200372	75 ea.	Curb Box – Top Section	_____	\$ _____	\$ _____
200373	75 ea.	Curb Box - Bottom Section	_____	\$ _____	\$ _____
200374	200 ea.	Valve Box – Lid Only	_____	\$ _____	\$ _____
200375	200 ea.	Valve Box - Top Section	_____	\$ _____	\$ _____
200376	125 ea.	Valve Box - Bottom Section	_____	\$ _____	\$ _____
200377	40 ea.	Valve Box Extension – 12”	_____	\$ _____	\$ _____
200378	20 ea.	Valve Box Extension – 18”	_____	\$ _____	\$ _____
201450	100 ea.	Pavadjusters – 1”	_____	\$ _____	\$ _____
201451	75 ea.	Pavadjusters – 1-1/2”	_____	\$ _____	\$ _____
201452	75 ea.	Pavadjusters – 2”	_____	\$ _____	\$ _____
201454	50 ea.	Pavadjusters – 3”	_____	\$ _____	\$ _____

GRAND TOTAL \$ _____

Are you bidding an approved item per bid specifications?

Yes () No ()

If No, please provide the manufacturer of product. _____

NOTE: Payment discount terms will not be considered in the award of this bid. Net 30 terms only will apply.

Note: Bid must be submitted in a sealed Envelope, directed to the attention of the Purchasing Manager, and marked in the Lower left-hand corner as follows:
“Quotation on Curb Boxes -Valve Boxes and Extensions and Pavadjusters due Wednesday, August 25, 2021 @ 10:00 a.m.”

DATE _____
 COMPANY _____
 ADDRESS _____
 STATE _____ ZIP _____

BY _____
(Signature)

NAME _____
(Type or Print)

TITLE _____

TELEPHONE _____

FAX _____

BEST SHIPPING SCHEDULE _____

EMAIL _____